

工业型号	公司型号	通俗命名	H	封装标识	包装方式	每管数量	每盒数量	每箱数量
FQP10N60C FQPF10N60C	H10N60P H10N60F	10N60	HAOHAI	P: TO-220P F: TO-220F	条管装 盒装箱装	50Pcs	1000Pcs	5000Pcs

■ Features

- Originative New Design
- Superior Avalanche Rugged Technology
- Robust Gate Oxide Technology
- Very Low Intrinsic Capacitances
- Excellent Switching Characteristics
- Unrivalled Gate Charge: 29nC(Typ.)
- Extended Safe Operating Area
- Lower $R_{DS(ON)}$: 0.67Ω(Typ.) @ $V_{GS}=10V$
- 100% Avalanche Tested
- Package: TO-220AB & TO-220F

■ 特点

导通电阻低、开关速度快、驱动简单、可并联使用、输入阻抗高、符合RoHS规范

■ 应用范围

开关电源、LCD电源、LED驱动电源、机箱电源、UPS电源、各种充电器、电子整流器、电子变压器、逆变器、控制器、转换器、风扇控制板、以及电源适配器、汽车稳压器等线性放大和功率开关电路

■ 封装形式

TO-220P 或 TO-220AB (半塑封)
TO-220F 或 TO-220FP (全塑封)

$I_D=9.5A$
 $BV_{DSS}=600V$
 $R_{DS(on)}=0.67\Omega$

10N60 Series Pin Assignment



3-Lead Plastic TO-220AB
Package Code: P
Pin 1: Gate
Pin 2 & Tab: Drain
Pin 3: Source



3-Lead Plastic TO-220FP
Package Code: F
Pin 1: Gate
Pin 2: Drain
Pin 3: Source

Series Symbol: 

■ Absolute Maximum Ratings ($T_C=25^\circ C$ unless otherwise specified)

Symbol	Parameter	Value		Units
		TO-220AB	TO-220F	
V_{DSS}	Drain-Source Voltage	600	600	V
I_D	Drain Current—Continuous ($T_C=25^\circ C$)	9.5	9.5*	A
	Drain Current—Continuous ($T_C=100^\circ C$)	5.7	5.7*	
I_{DM}	Drain Current – Pulsed (Note 1)	38	38*	
V_{GS}	Gate-Source Voltage	±30	±30	V
E_{AS}	Single Pulsed Avalanche Energy (Note 2)	700	700	mJ
I_{AR}	Avalanche Current (Note 1)	9.5	9.5	A
E_{AR}	Repetitive Avalanche Energy (Note 1)	15.6	15.6	mJ
dv/dt	Peak Diode Recovery dv/dt (Note 3)	4.5	4.5	V/ns
P_D	Power Dissipation ($T_C=25^\circ C$)	156	50	W
	Power Dissipation - Derate above 25°C	1.25	0.4	
T_J, T_{STG}	Operating and Storage Temperature Range	-50 ~ +150		°C
T_L	Maximum lead temperature for soldering purposes, 1/8" from case for 5 seconds	300		

* Drain current limited by maximum junction temperature (TO-220F)

■ Thermal Resistance Characteristics

Symbol	Parameter	TO-220AB		TO-220F		Units
		Typ.	Max.	Typ.	Max.	
$R_{\theta JC}$	Junction-to-Case	--	0.80	--	2.50	°C/W
$R_{\theta CS}$	Case-to-Sink	0.5	--	--	--	
$R_{\theta JA}$	Junction-to-Ambient	--	62.5	--	62.5	

Electrical Characteristics ($T_C=25^\circ\text{C}$ unless otherwise specified)

Symbol	Parameter	Test Conditions	Min.	Typ.	Max.	Units
--------	-----------	-----------------	------	------	------	-------

On Characteristics

V_{GS}	Gate Threshold Voltage	$V_{DS}=V_{GS}, I_D=250\mu\text{A}$	2.5	--	4.0	V
$R_{DS(ON)}$	Static Drain-Source On-Resistance	$V_{GS}=10\text{V}, I_D=4.75\text{A}$	--	0.67	0.80	Ω

Off Characteristics

BV_{DSS}	Drain-Source Breakdown Voltage	$V_{GS}=0\text{V}, I_D=250\mu\text{A}$	600	--	--	V
$\Delta BV_{DSS}/\Delta T_J$	Breakdown Voltage Temperature Coefficient	$I_D=250\mu\text{A}$, Referenced to 25°C	--	0.70	--	$\text{V}/^\circ\text{C}$
I_{DSS}	Zero Gate Voltage Drain Current	$V_{DS}=600\text{V}, V_{GS}=0\text{V}$	--	--	1	μA
		$V_{DS}=480\text{V}, T_C=125^\circ\text{C}$	--	--	10	
I_{GSSF}	Gate-Body Leakage Current, Forward	$V_{GS}=+30\text{V}, V_{DS}=0\text{V}$	--	--	100	nA
I_{GSSR}	Gate-Body Leakage Current, Reverse	$V_{GS}=-30\text{V}, V_{DS}=1\text{V}$	--	--	-100	

Dynamic Characteristics

C_{iss}	Input Capacitance	$V_{DS}=25\text{V}$ $V_{GS}=0\text{V}$ $f=1.0\text{MHz}$	--	1450	1885	μF
C_{oss}	Output Capacitance		--	145	190	
C_{riss}	Reverse Transfer Capacitance		--	13	17	

Switching Characteristics

$t_{d(on)}$	Turn-On Time	$V_{DS}=300\text{V}$ $I_D=9.5\text{A}$ $R_G=25\Omega$ (Note 4,5)	--	23	55	nS
t_r	Turn-On Rise Time		--	69	150	
$t_{d(off)}$	Turn-Off Delay Time		--	144	300	
t_f	Turn-Off Fall Time		--	77	165	
Q_g	Total Gate Charge	$V_{DS}=480\text{V}$ $I_D=9.5\text{A}, V_{GS}=10\text{V}$ (Note 4,5)	--	29	38	nC
Q_{gs}	Gate-Source Charge		--	6.8	--	
Q_{gd}	Gate-Drain Charge		--	10.3	--	

Source-Drain Diode Maximum Ratings and Characteristics

I_S	Continuous Source-Drain Diode Forward Current	--	--	9.5	A	
I_{SM}	Pulsed Source-Drain Diode Forward Current	--	--	38		
V_{SD}	Source-Drain Diode Forward Voltage	$I_S=9.5\text{A}, V_{GS}=0\text{V}$	--	--	1.4	V
t_{rr}	Reverse Recovery Time	$I_S=9.5\text{A}, V_{GS}=0\text{V}$ $di_F/dt=100\mu\text{A}/\mu\text{s}$ (Note 4)	--	420	--	nS
Q_{rr}	Reverse Recovery Charge		--	4.2	--	μC

Notes:

1. Repetitive Rating: Pulse width limited by maximum junction temperature ; 2. $L=14.2\text{mH}, I_{AS}=9.5\text{A}, V_{DD}=50\text{V}, R_G=25\Omega$, Starting $T_J=25^\circ\text{C}$
3. $I_{SD} \leq 9.5\text{A}, di/dt \leq 200\text{A}/\mu\text{s}, V_{DD} \leq BV_{DSS}$, Starting $T_J=25^\circ\text{C}$; 4. Pulse Test: Pulse Width $\leq 300\mu\text{s}$, Duty Cycle $\leq 2\%$; 5. Essentially Independent of Operating Temperature

Typical Performance Characteristics

Fig-1. On Region Characteristics

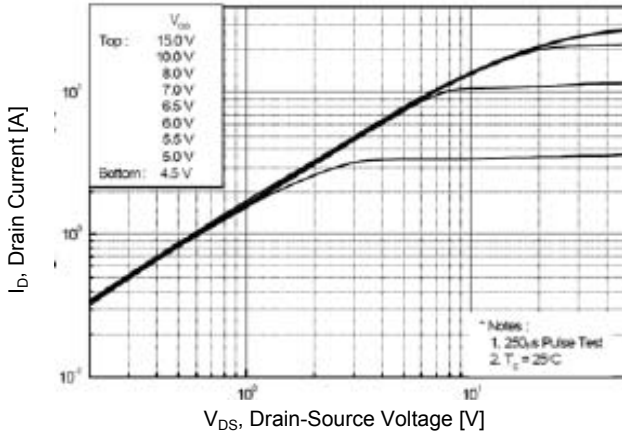

Fig-2. Transfer Characteristics

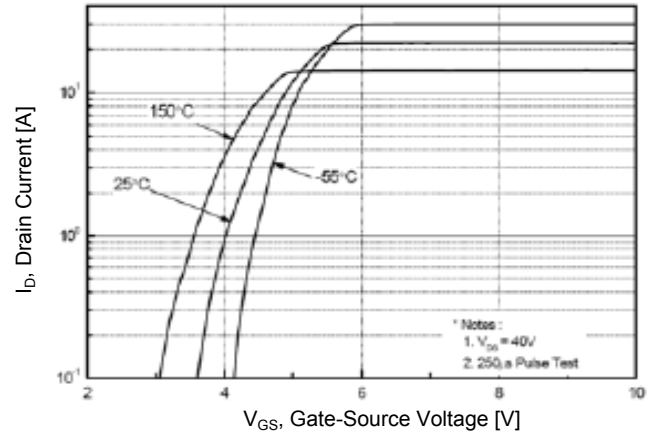

Fig-3. On Resistance Variation vs Drain Current and Gate Voltage

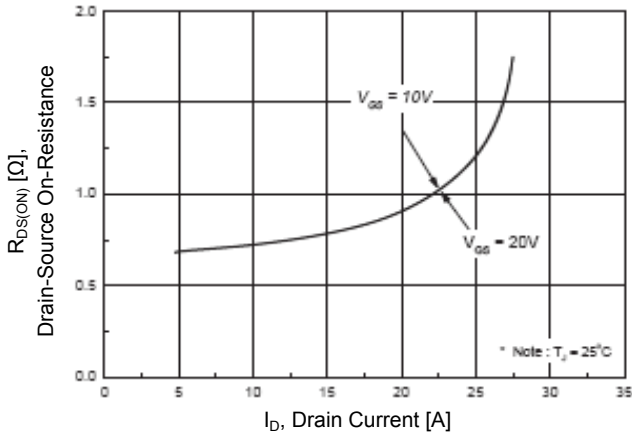

Fig-4. Body Diode Forward Voltage Variation with Source Current and Temperature

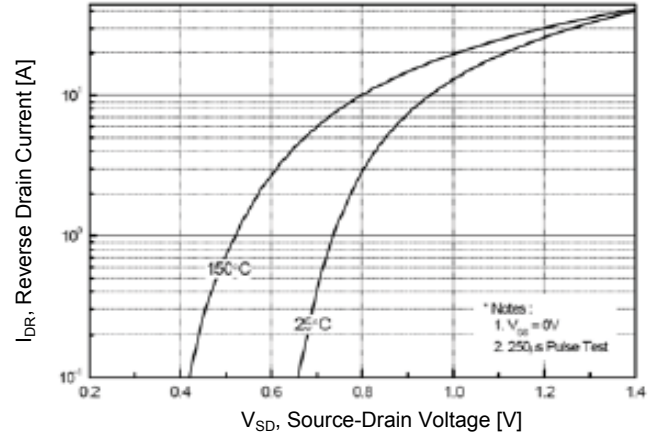

Fig-5. Capacitance Characteristics

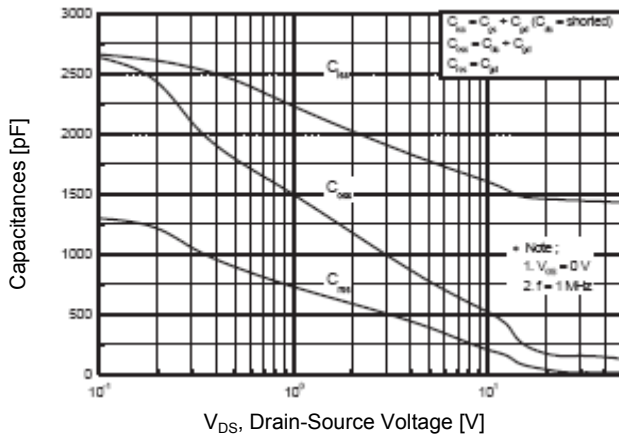
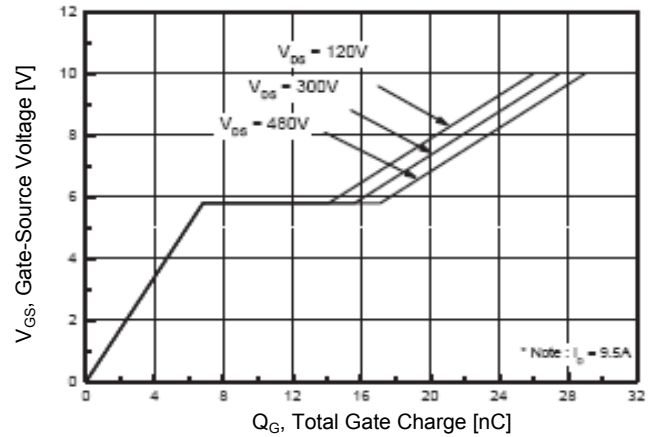

Fig-6. Gate Charge Characteristics



Typical Performance Characteristics (Continued)

Fig-7. Breakdown Voltage Variation vs Temperature

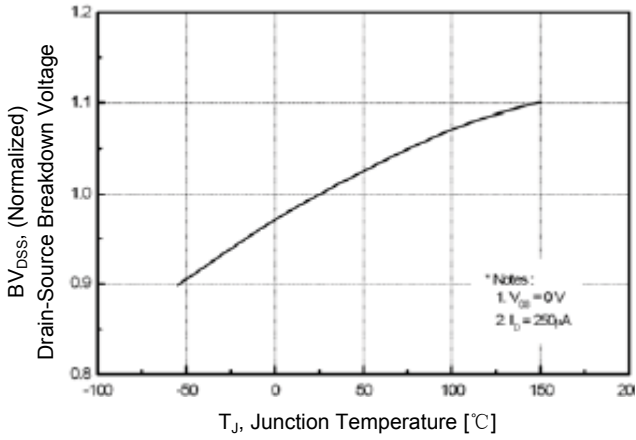

Fig-8. On-Resistance Variation vs Temperature

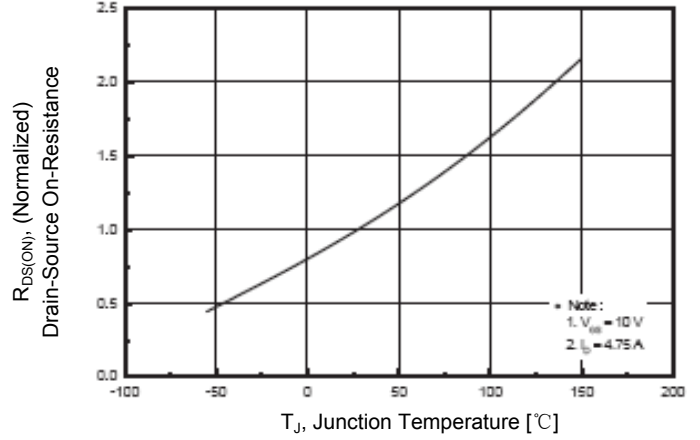

Fig-9. Maximum Safe Operating Area

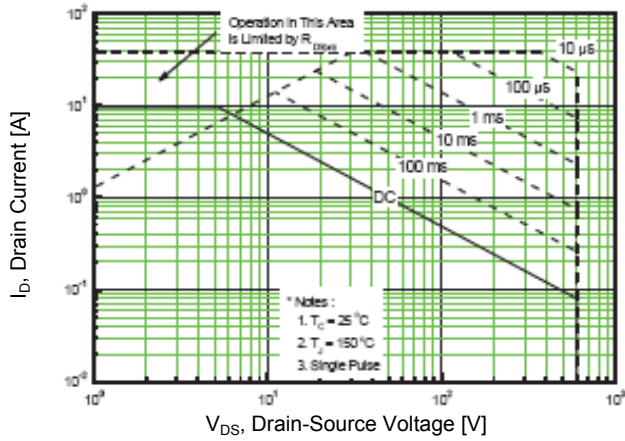

Fig-10. Maximum Drain Current vs Case Temperature

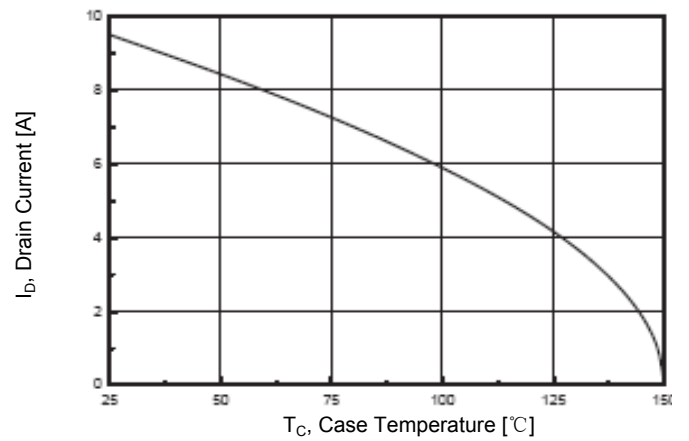

Fig-11. Transient Thermal Response Curve

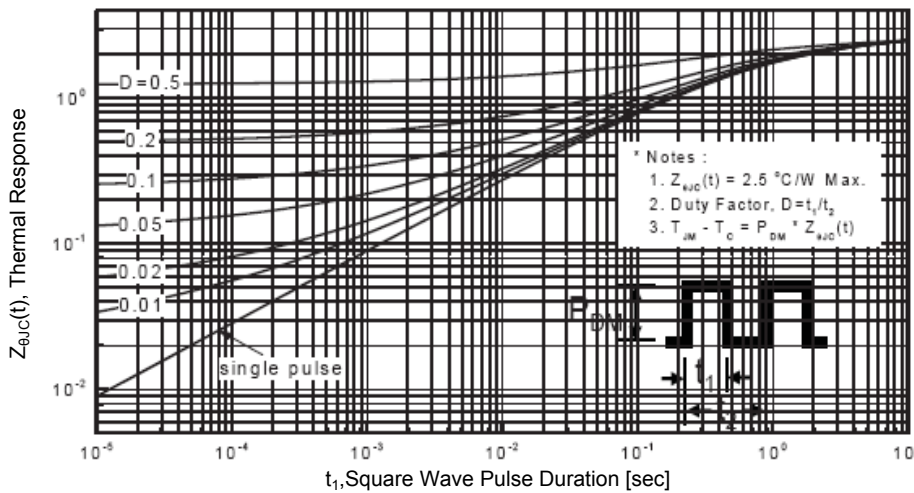

Fig-12. Gate Charge Test Circuit & Waveform

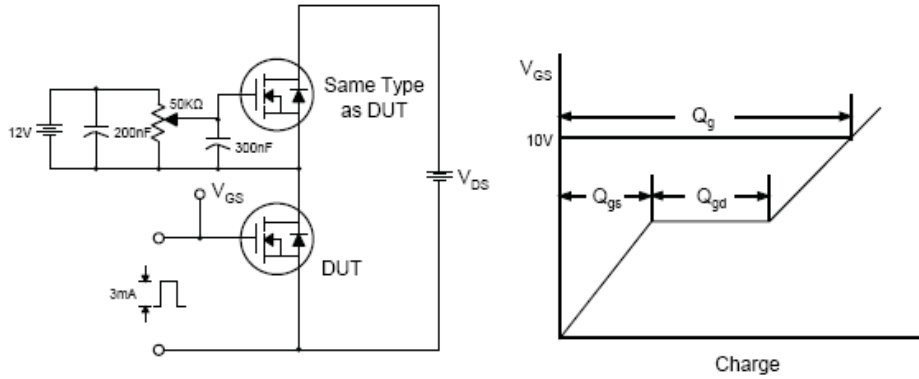

Fig-13. Resistive Switching Test Circuit & Waveforms

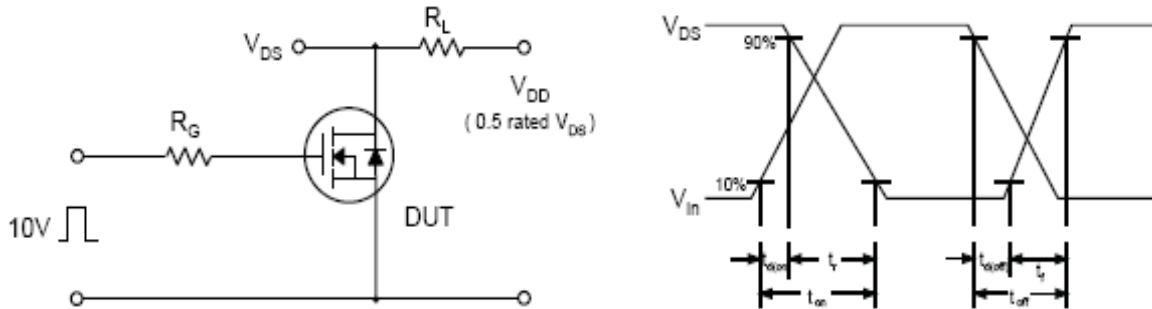

Fig-14. Unclamped Inductive Switching Test Circuit & Waveforms

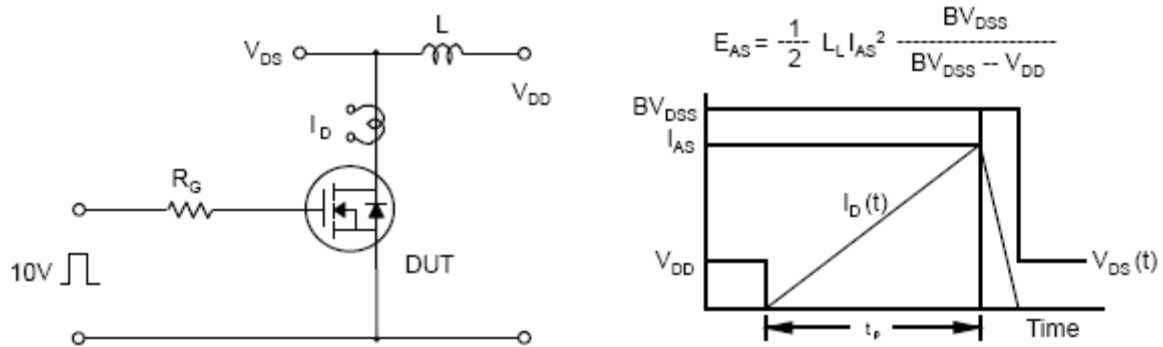
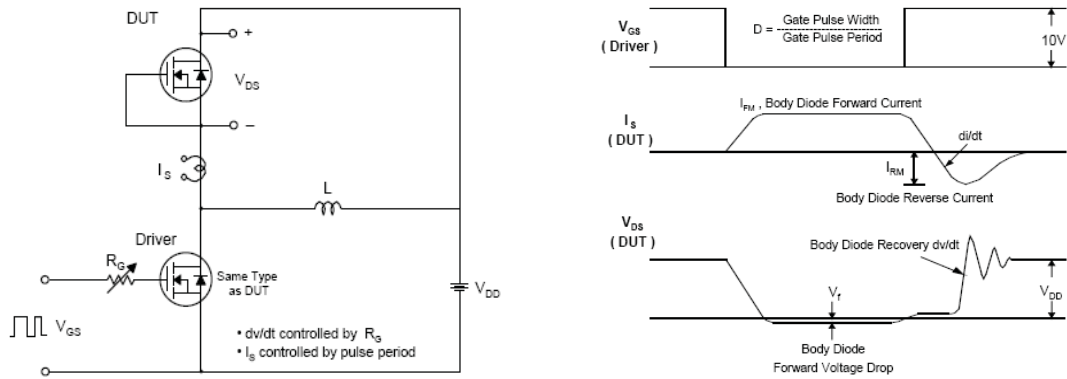

Fig-15. Peak Diode Recovery dv/dt Test Circuit & Waveforms



PACKAGE DIMENSIONS

■ TO-220P (TO-220AB) Dimension (封装尺寸数据, 单位: mm)				元件打印标识
	DIM	Min.	Max.	<p>左上角: LOGO AAA: 芯片代码 BBBBB: 批次识别码 aabb: 生产批号 其中: aa: 出厂年份 bb: 出厂自然周 (01~53) XXXXXXXX: 器件型号</p>
	A	6.48	7.40	
	C	4.40	4.90	
	D	2.34	3.00	
	E	0.45	0.80	
	F	9.80	10.36	
	G	3.10	3.60	
	I	2.70	3.43	
	J	0.60	1.00	
	K	2.34	2.74	
	L	12.48	13.60	
	M	15.67	16.20	
	N	0.90	1.47	
	O	2.00	2.96	
	$\alpha 1/2/4/5$	-	*5°	
$\alpha 3$	-	*27°		

■ TO-220F (TO-220FP) Dimension (封装尺寸数据, 单位: mm)				元件打印标识
	DIM	Min.	Max.	<p>左上角: LOGO AAA: 芯片代码 XXXXXXXX: 器件型号 BBBBB: 批次识别码 aabb: 生产批号 其中: aa: 出厂年份 bb: 出厂自然周 (01~53)</p>
	A	5.58	7.49	
	B	8.38	8.90	
	C	4.40	4.70	
	D	1.15	1.39	
	E	0.35	0.60	
	F	2.03	2.92	
	G	9.66	10.28	
	H	--	*16.25	
	I	--	*3.83	
	J	3.00	4.00	
	K	0.75	0.95	
	L	2.54	3.42	
	M	1.14	1.40	
	N	--	*2.54	
O	12.70	14.27		
P	14.48	15.87		

Manufacturers version information

2010-07-05, HAOHAI™ Product Data-S1.0

2014-06-05, HAOHAI™ Product Data-D1.0



经中华人民共和国工商行政管理总局商标局批准

HAOHAI、HHE 图案、字母、均为我公司正式注册商标，仿冒、盗用均属侵权，违法必究！

WARN: Letters, patterns, are officially registered my trademark counterfeiting, theft are all violations, violators will be held liable !

深圳市浩海电子有限公司

SHENZHEN HAOHAI ELECTRONICS CO., LTD.

2 floor(whole floor), BAOXIN Building, 0 Lane on the 8th, Yufeng Garden,
82 District, BAOAN District, Shenzhen City, Guangdong Province, China.

中國 廣東省 深圳市 寶安區 82区 裕豐花園 零巷8號 寶馨樓 二楼 (全层)

公司电话 TEL: +86-755-29955080、29955081、29955082、29955083

总机八线 29955090、29955091、29955092、29955093

FAX: +86-755-27801767

E-mail:kkg@kkg.com.cn

<http://www.szhhe.com>

<http://www.kkg.com.cn>